

JAEGER

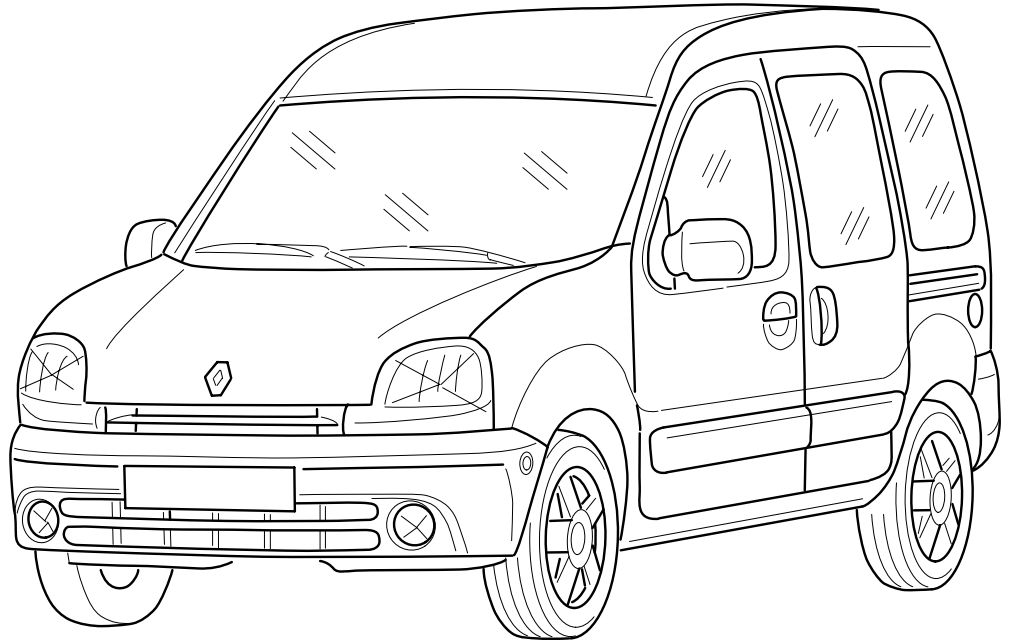

RENAULT KANGOO 1 Ph 1+2 04/98 >> 12/07

Ohne Überwachung der Anhänger-Blinkleuchten!

Without monitoring of the trailer turn signals!

735008

745008

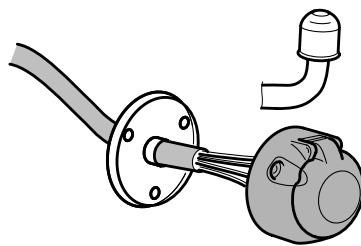

7-PIN

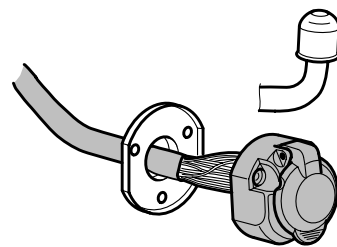
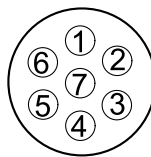

13-PIN

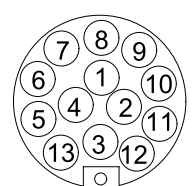

- (D)** Einbauanleitung
- (GB)** Fitting instructions
- (F)** Instructions de montage
- (E)** Instrucciones de montaje
- (NL)** Inbouwhandleiding
- (P)** Instruções de montagem
- (I)** Istruzioni di montaggio

- (CZ)** Pokyny pro montáž
- (H)** Felszerelési utasítás
- (PL)** Instrukcje wbudowania
- (GR)** Οδηγίες συναρμολογήσης
- (S)** Montageanvisning
- (SLO)** Navodila za instalacijo
- (TR)** Montaj talimatları

ERICH

735008

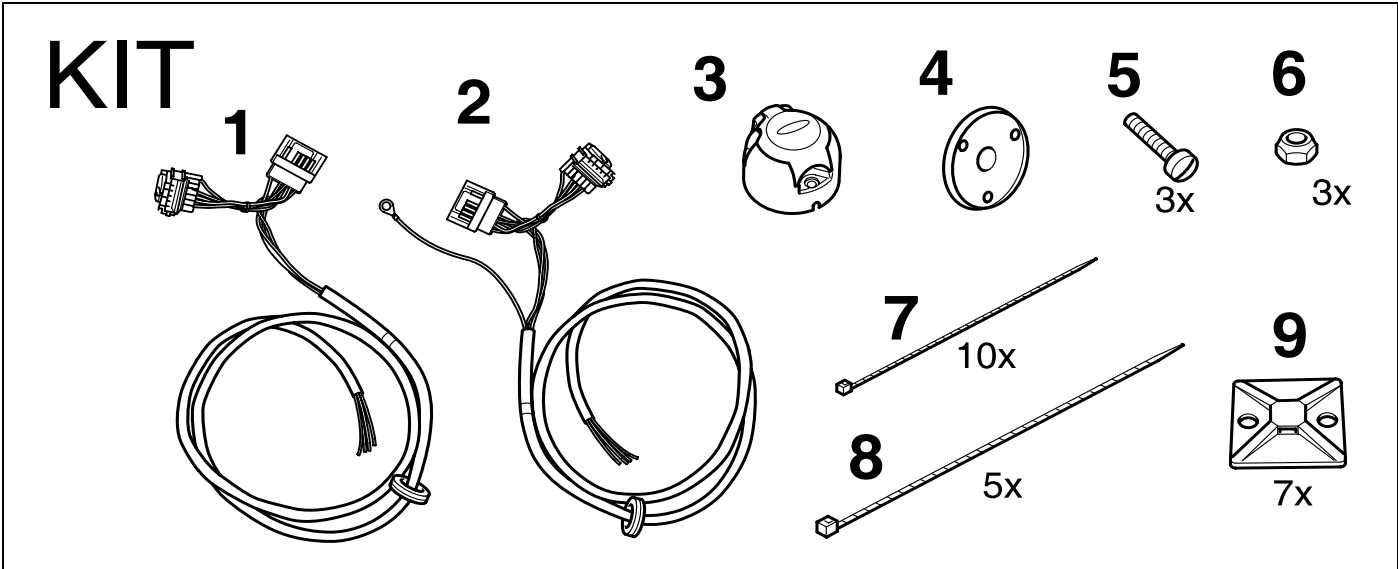

745008

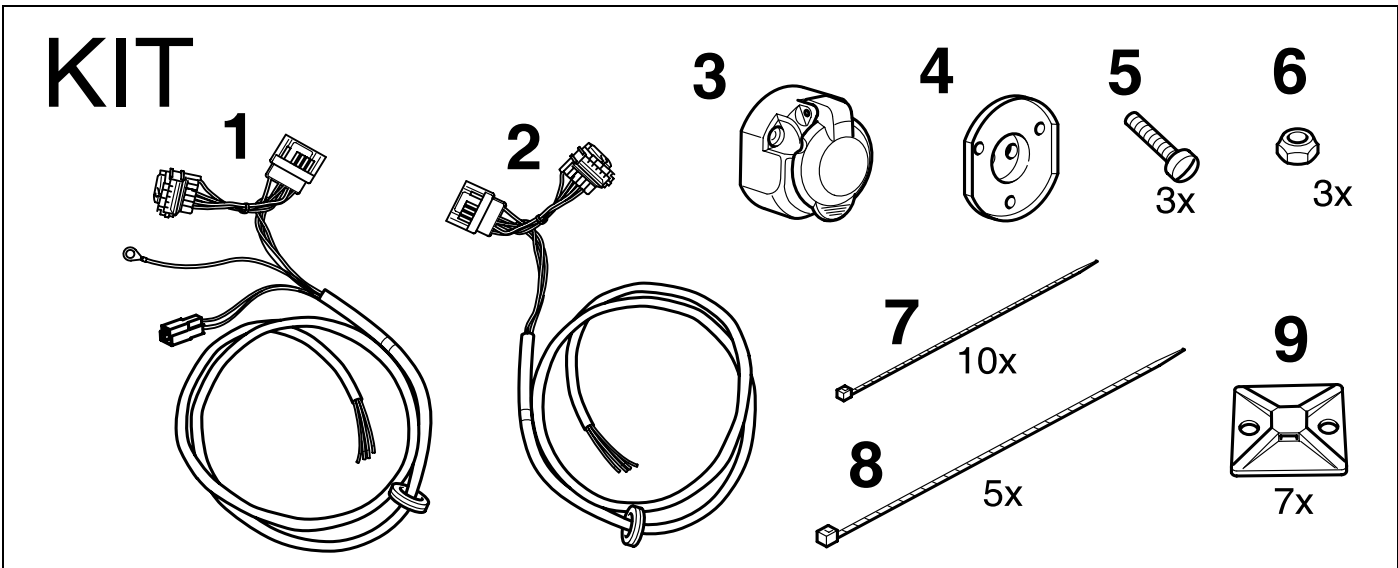

Tools

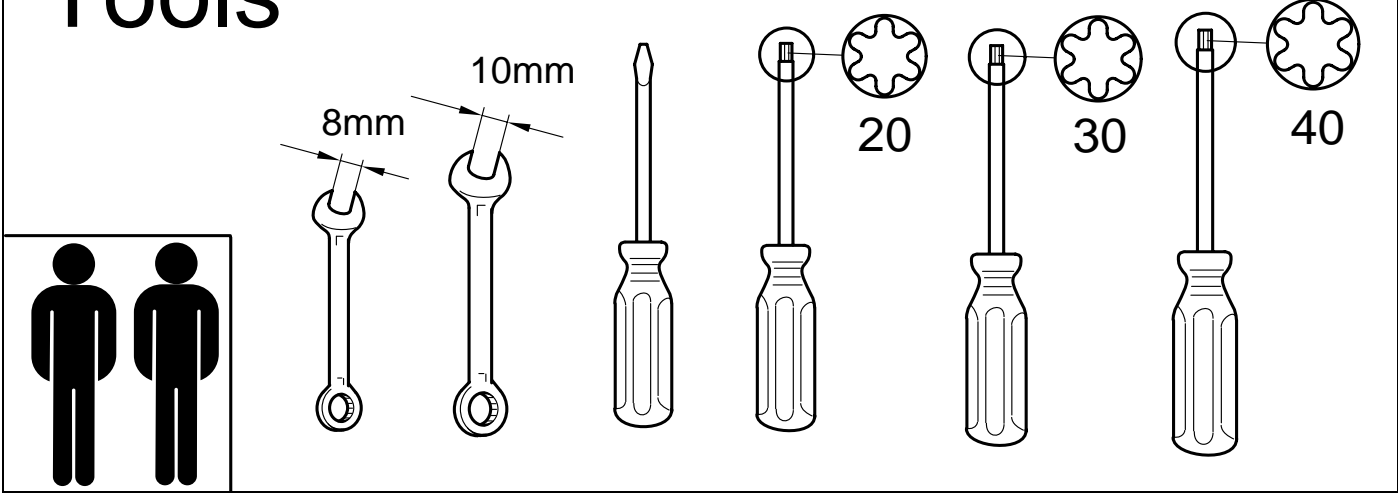

1

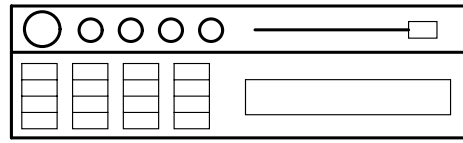
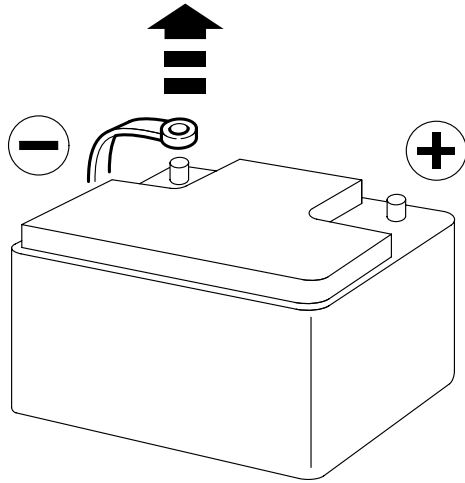

Radio Code

2

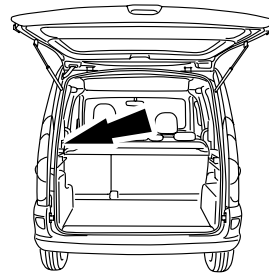
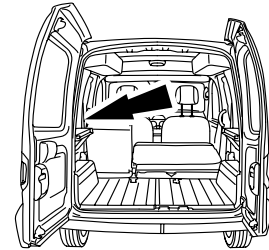
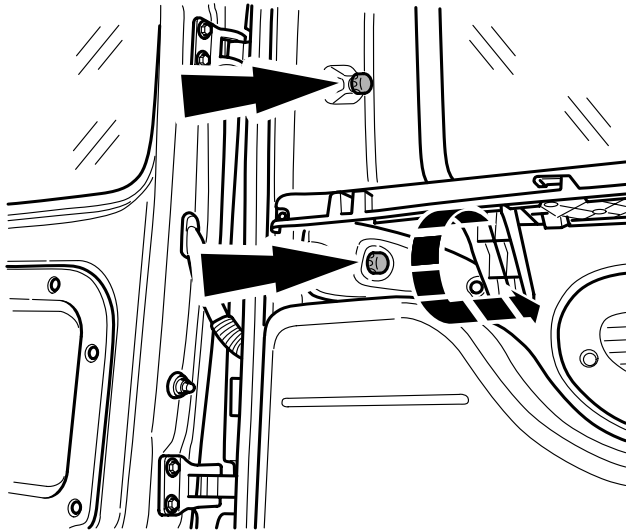

3

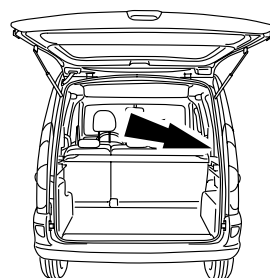
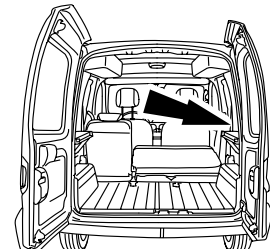
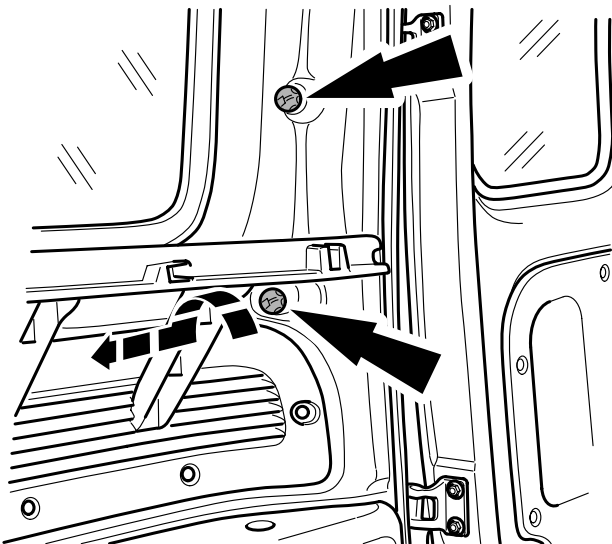

4

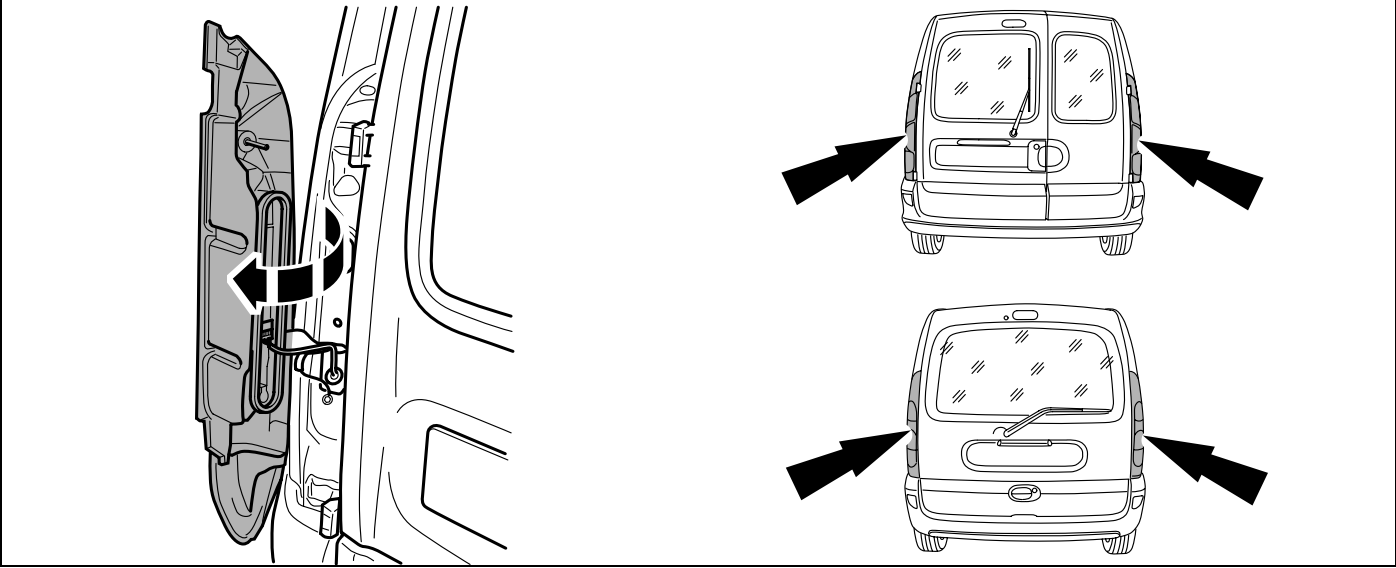

5

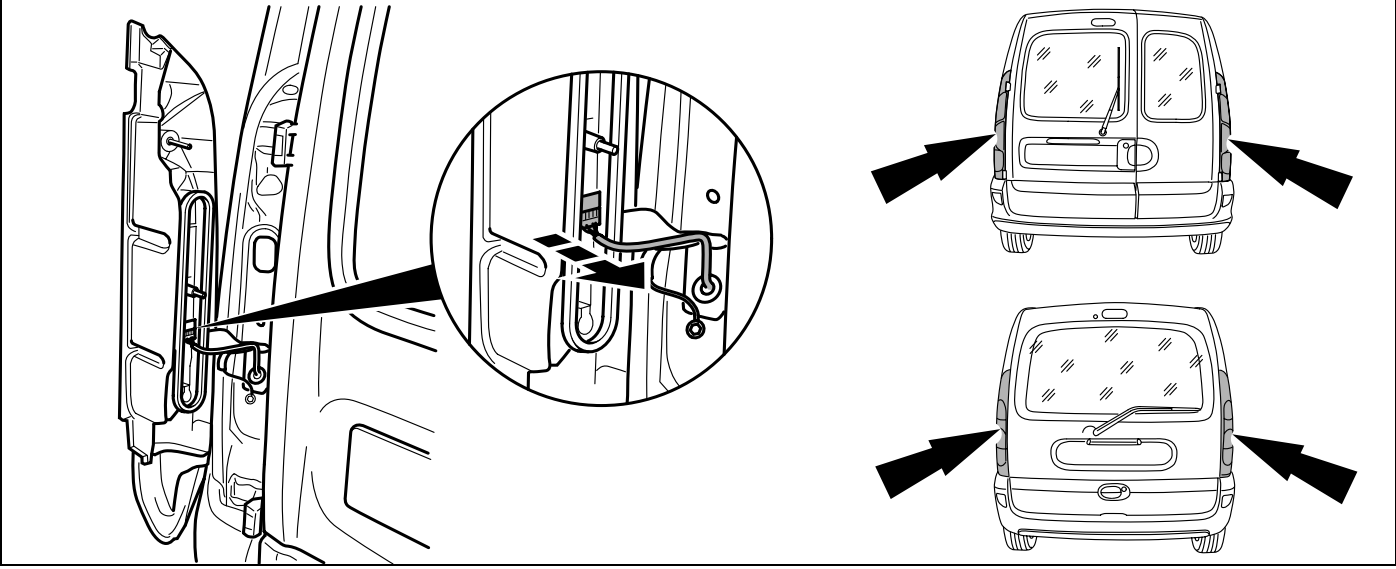

6

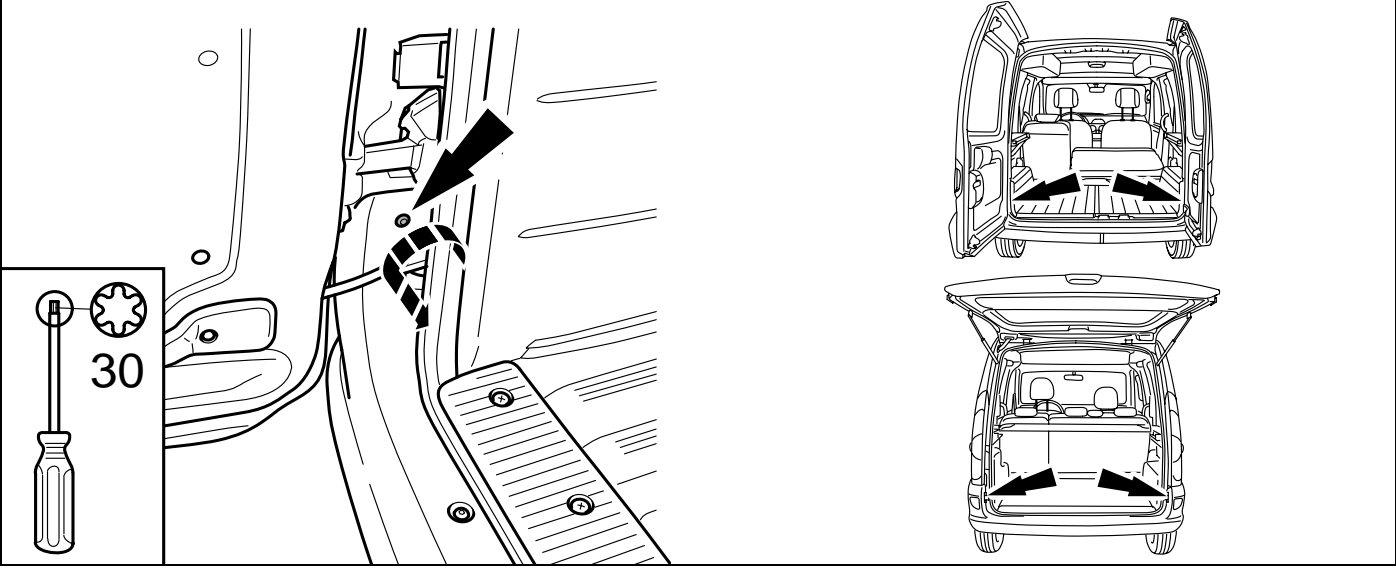

7

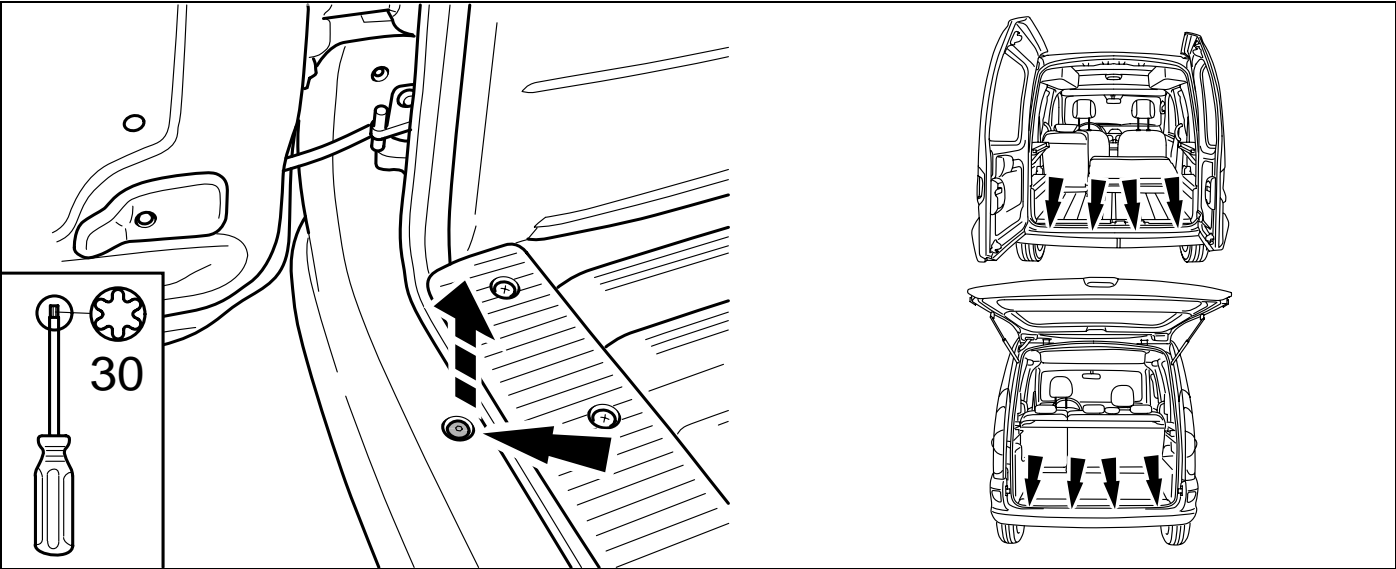

8

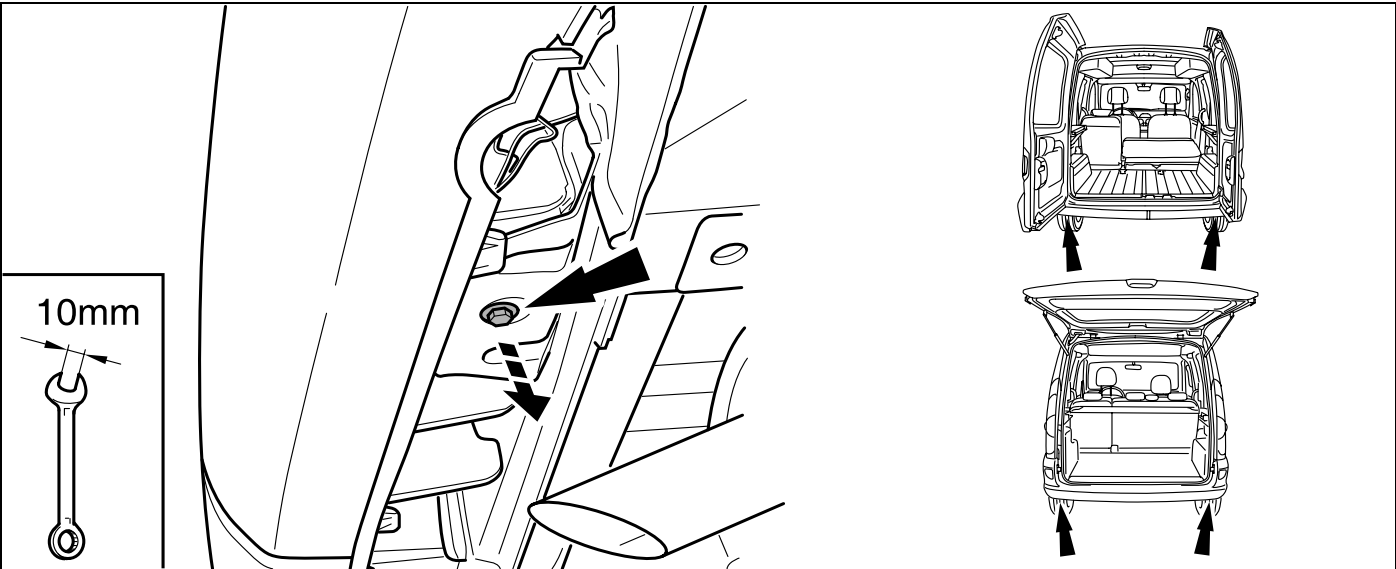

9

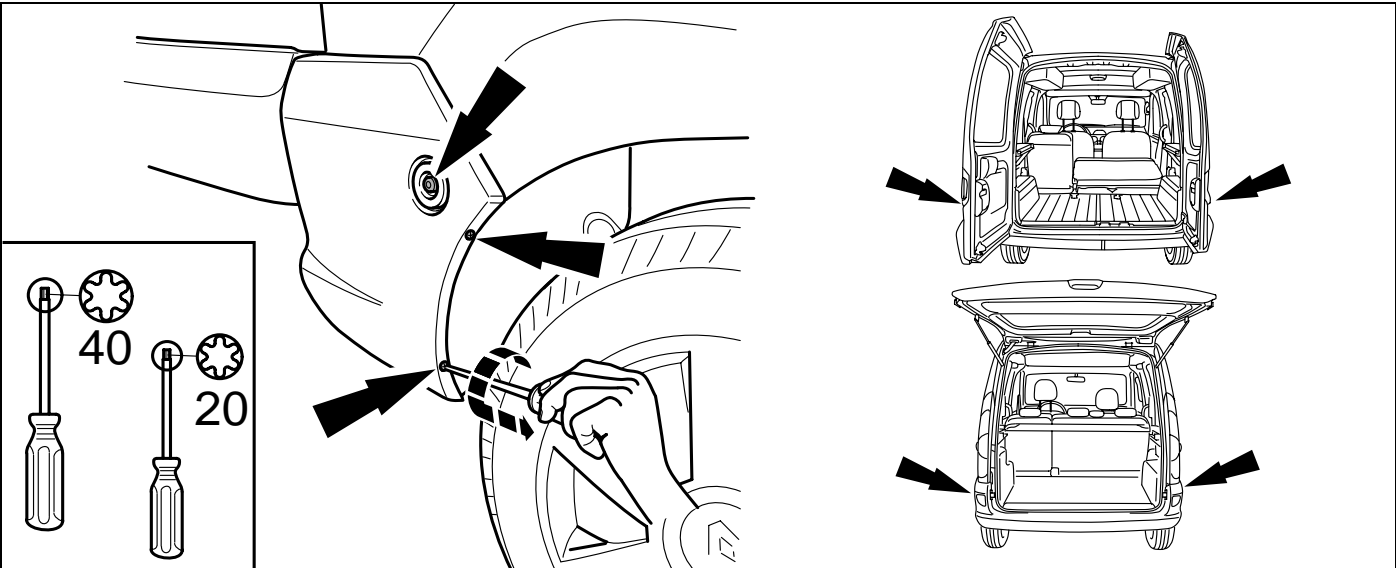

10

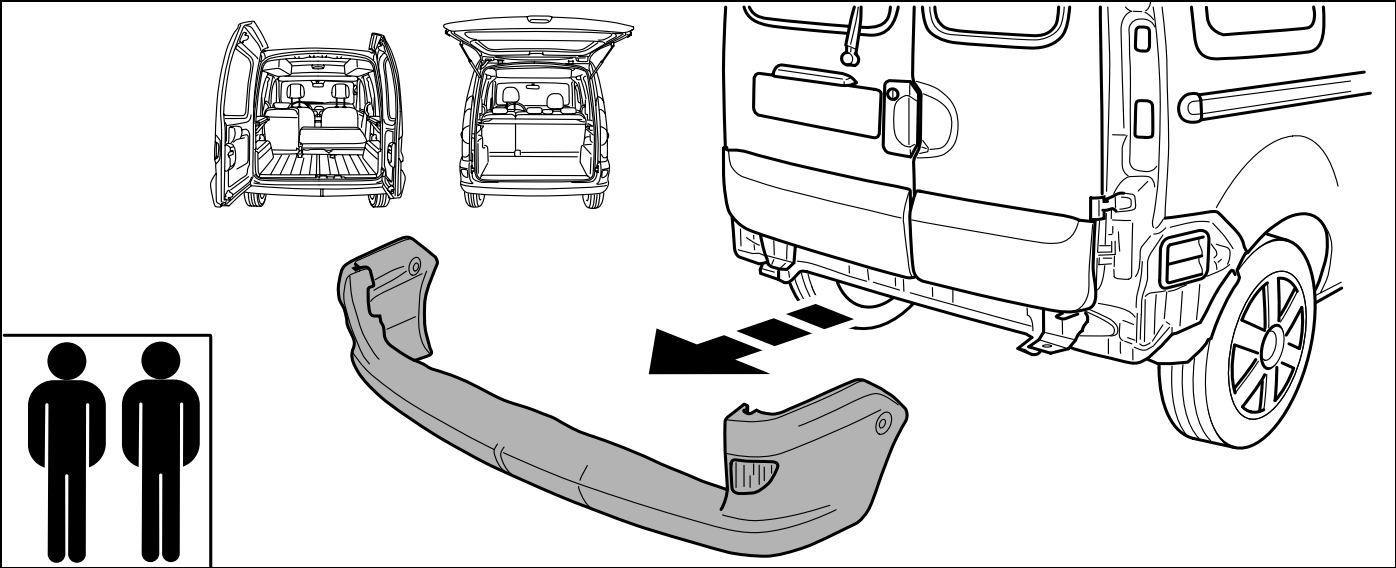

11

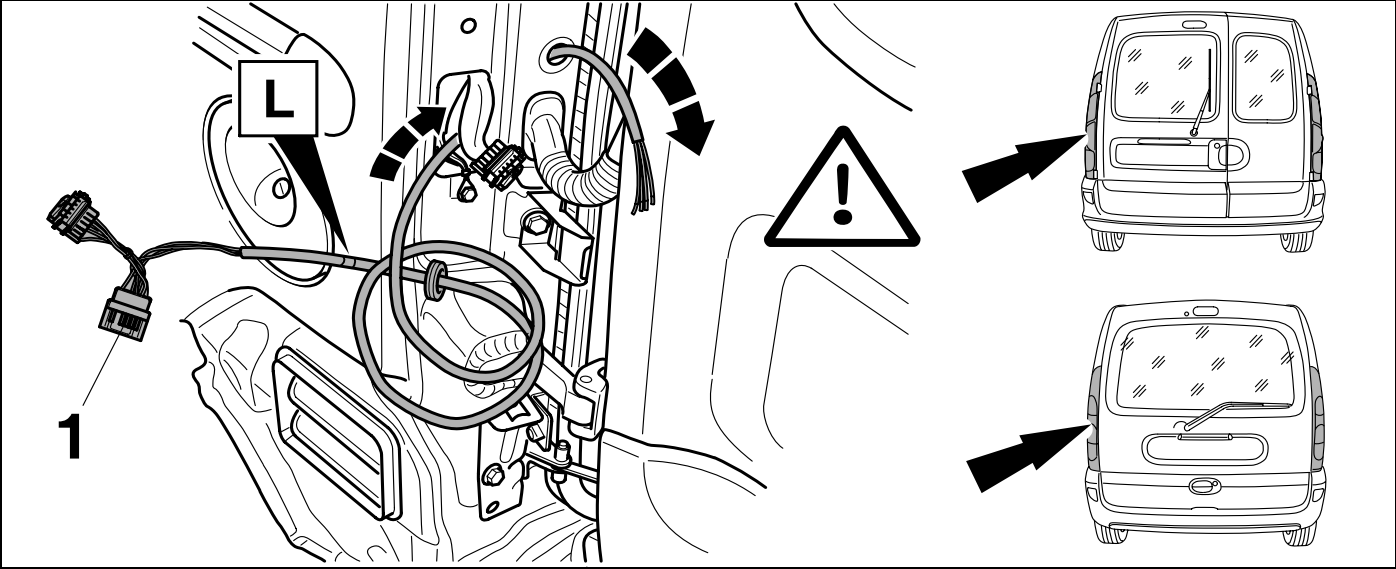

12

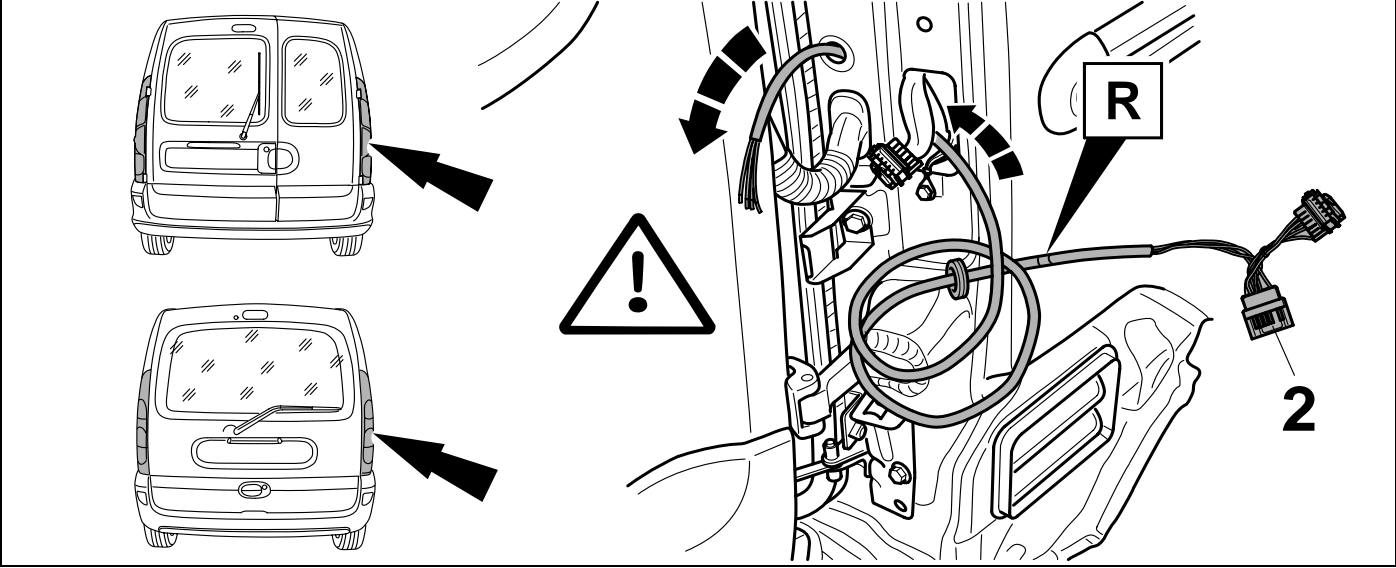

13

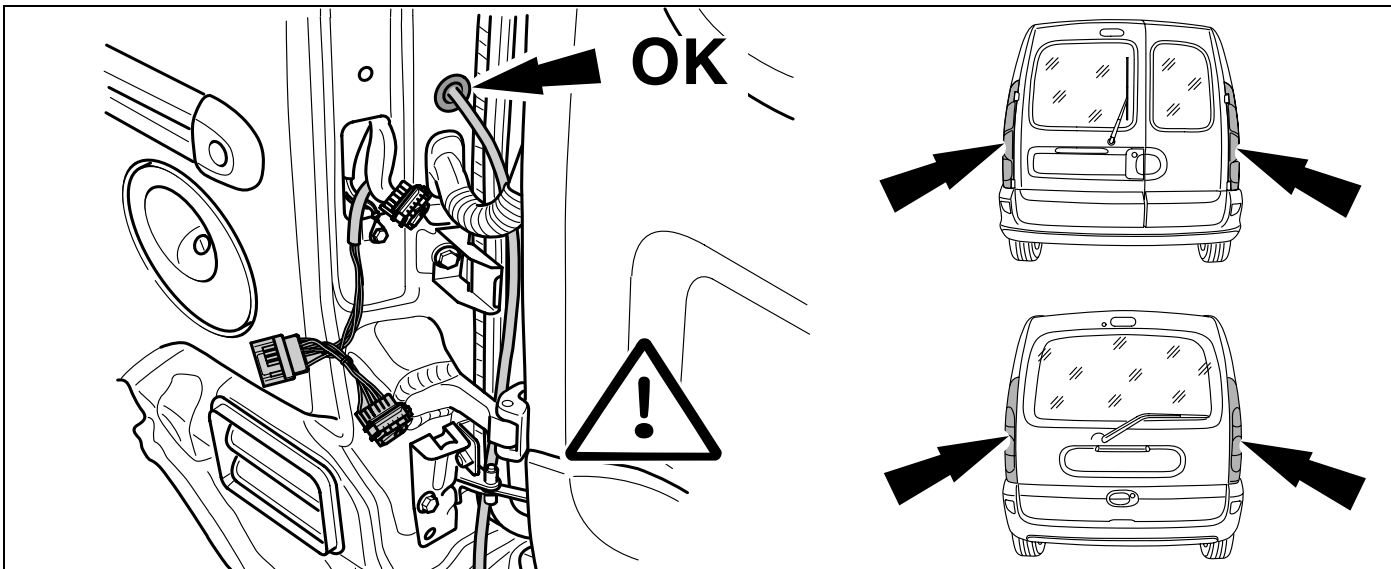

14

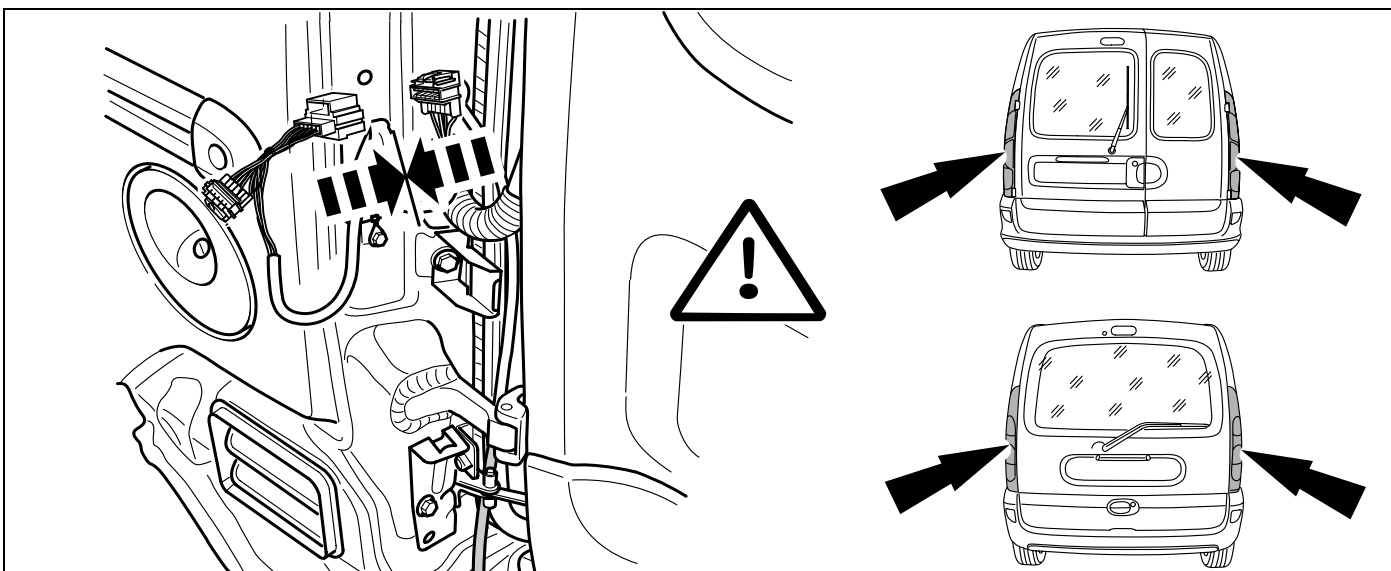

15

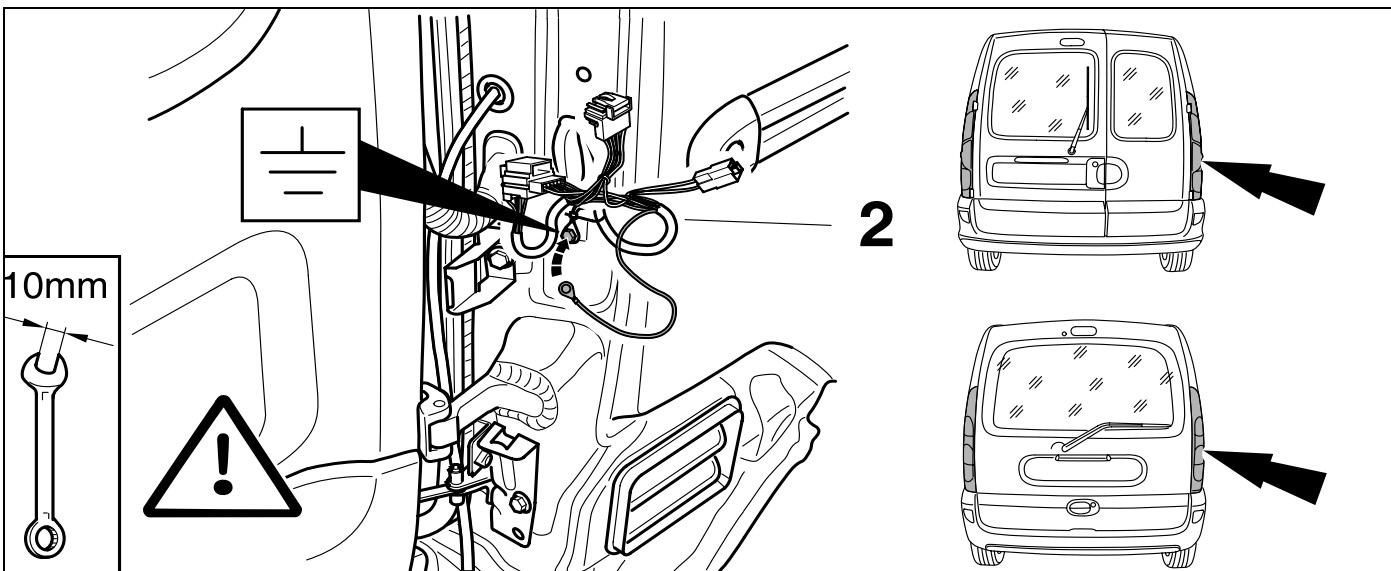

16

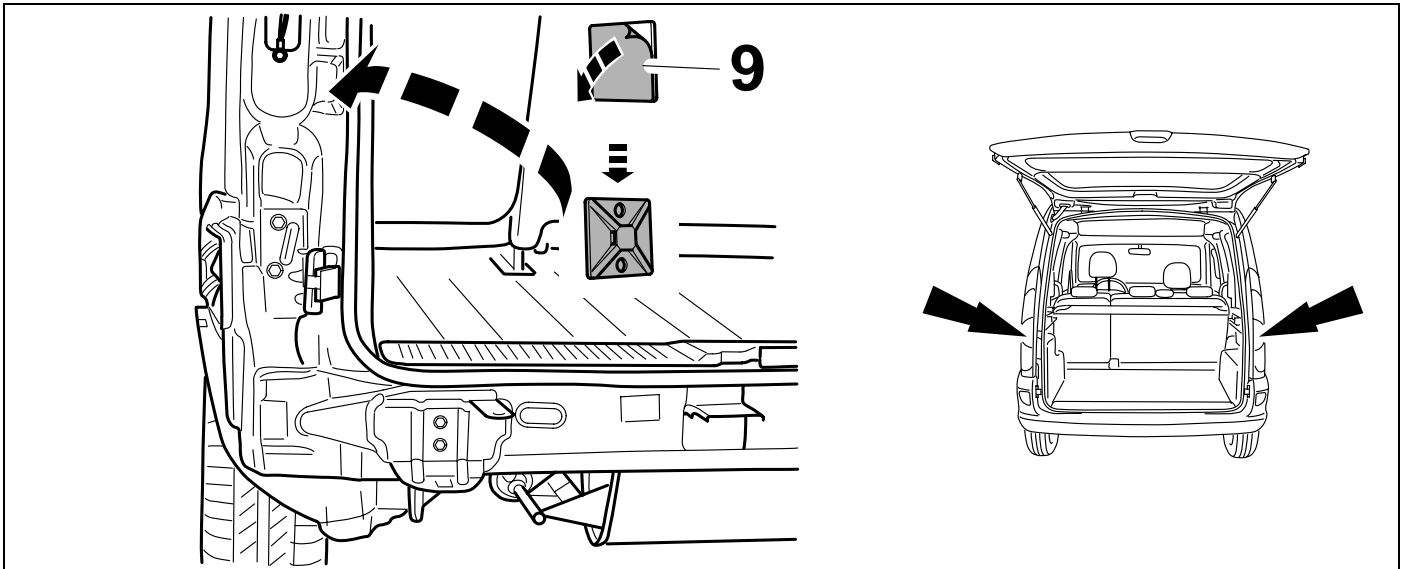

17

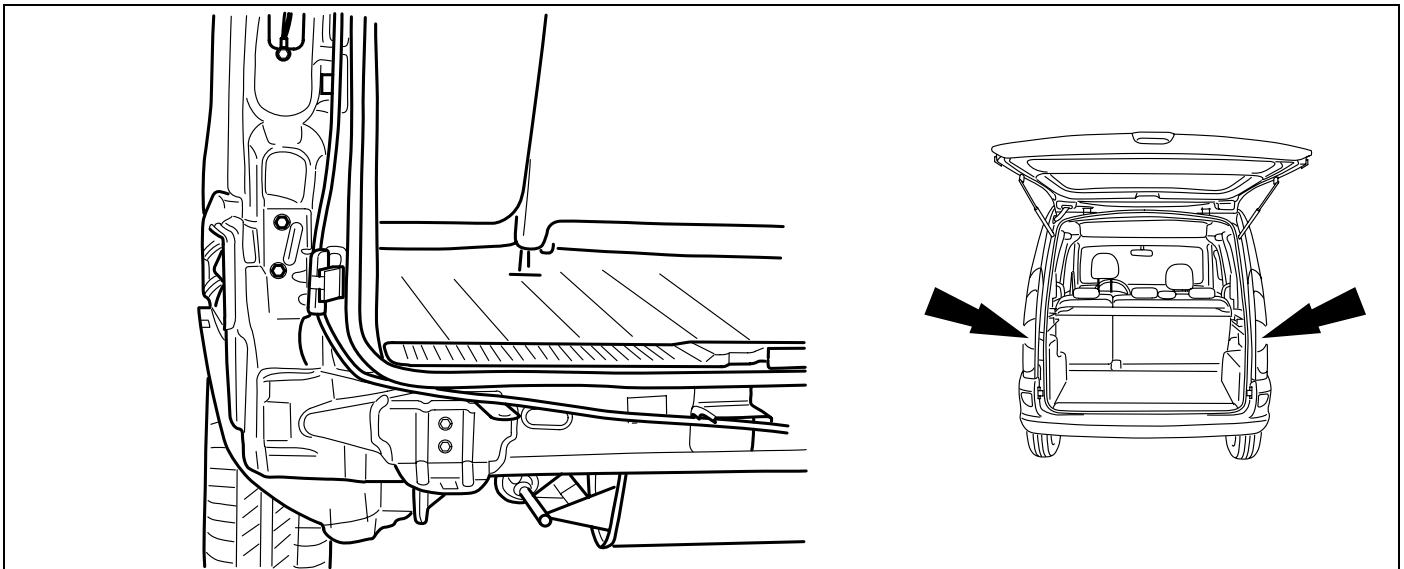

18

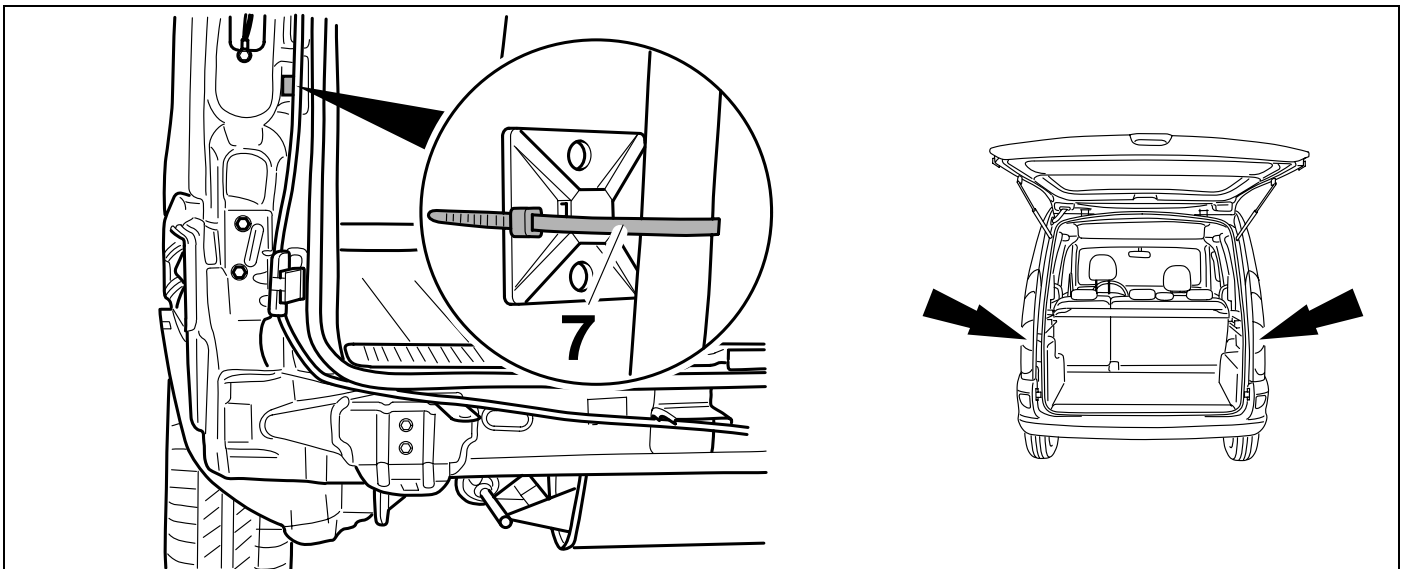

19

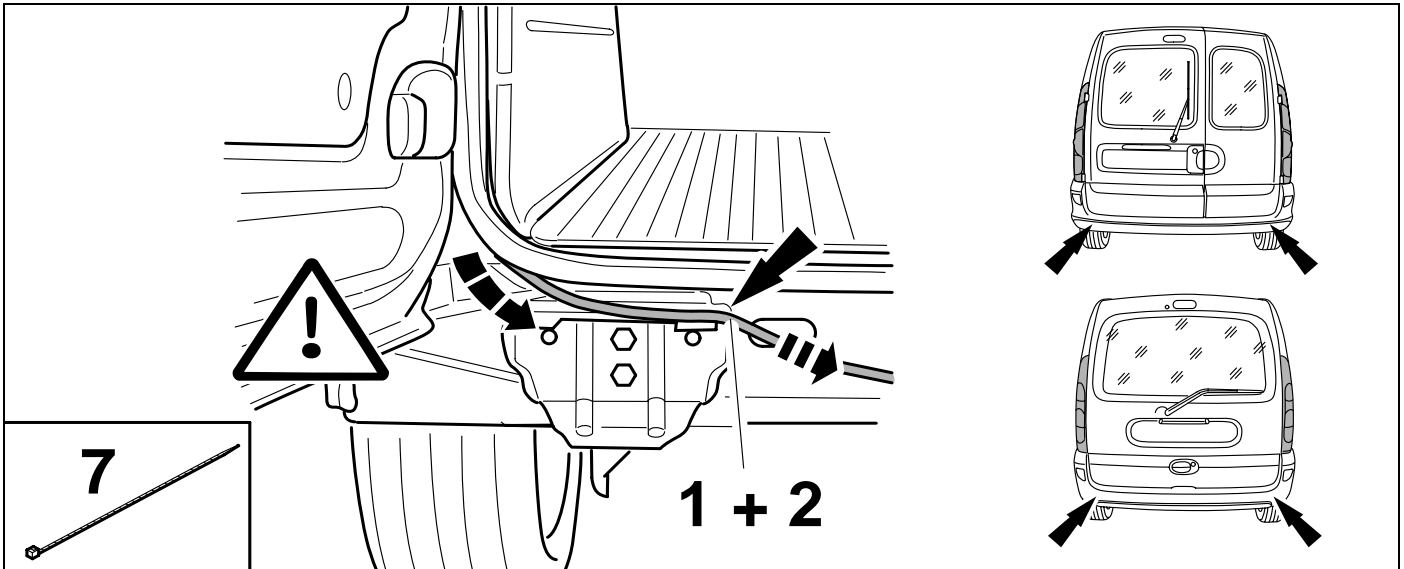

20

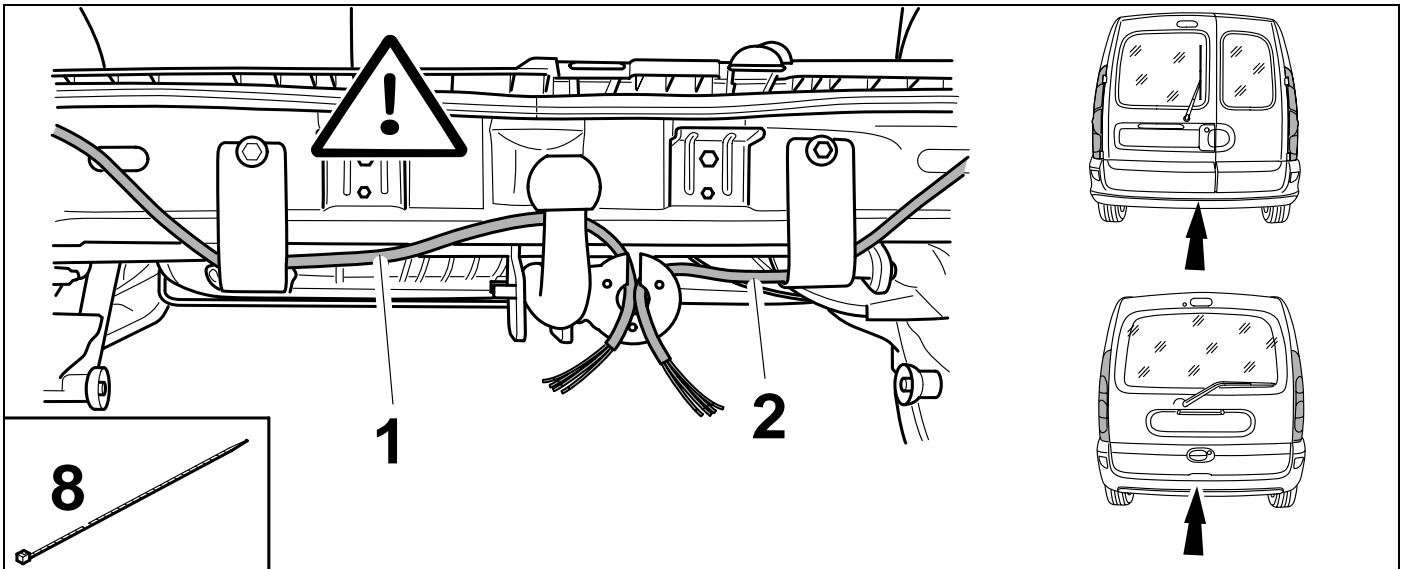

21

735008

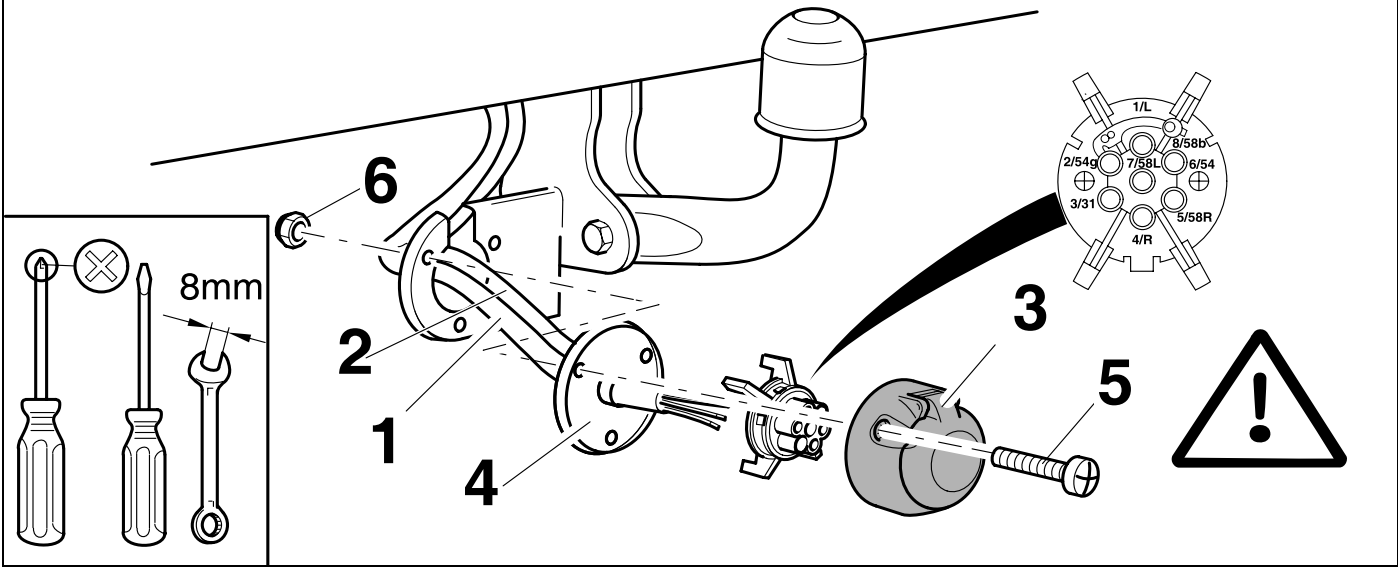

22

745008

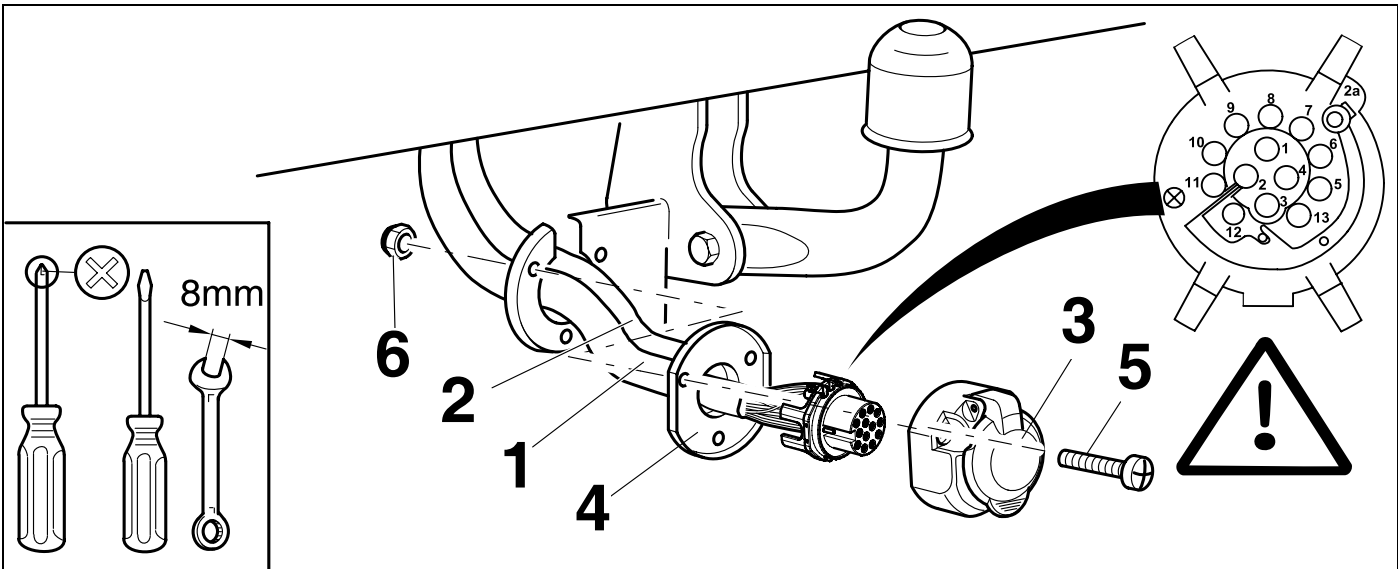

24

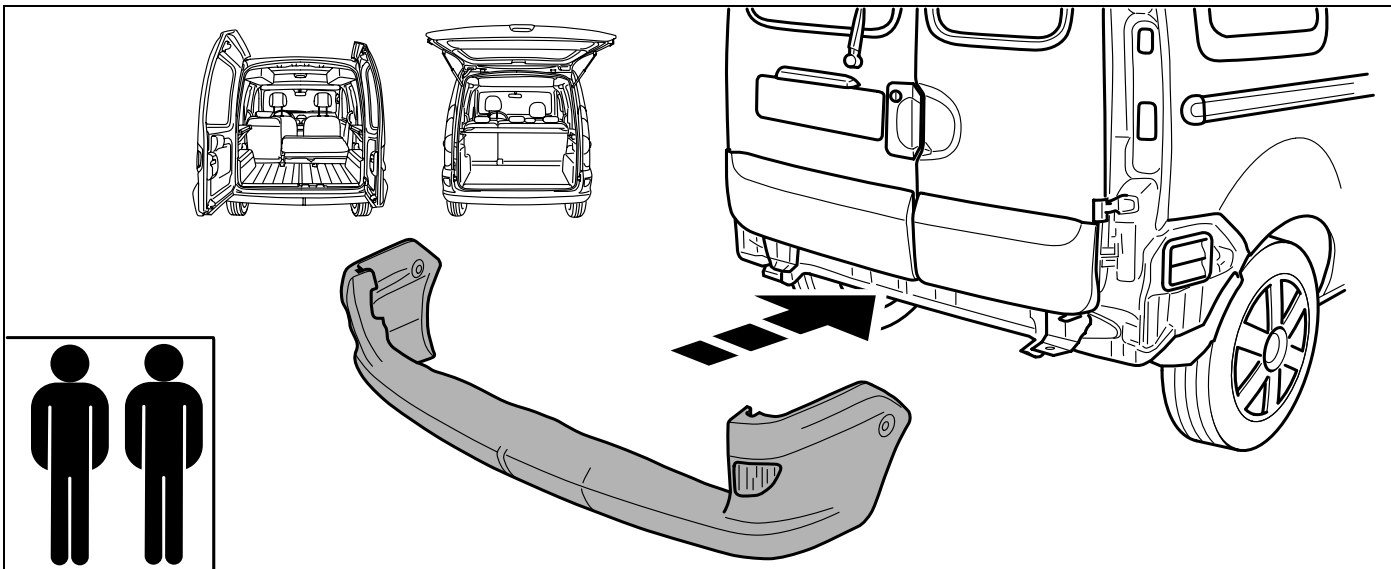

25

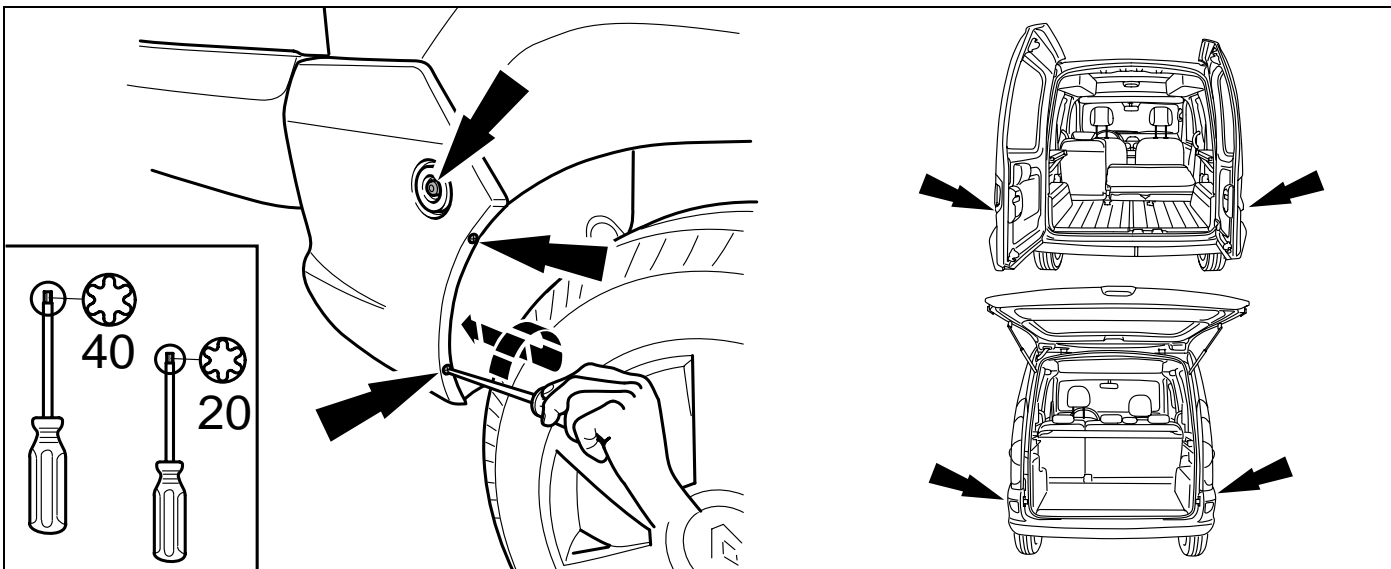

26

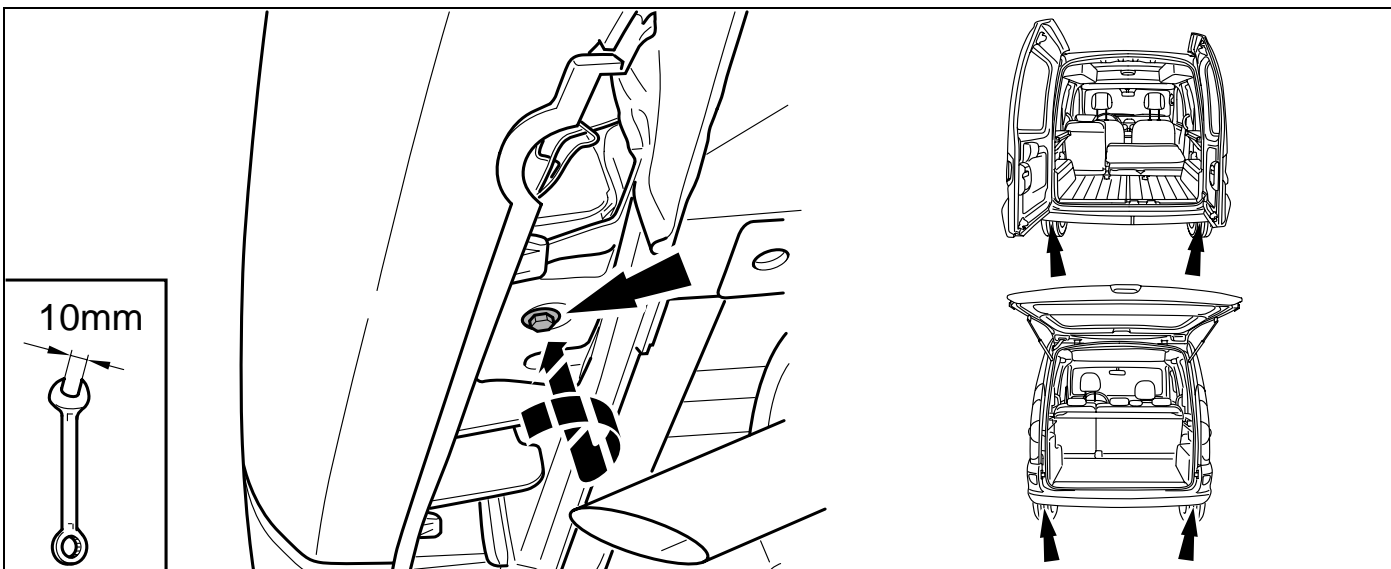

27

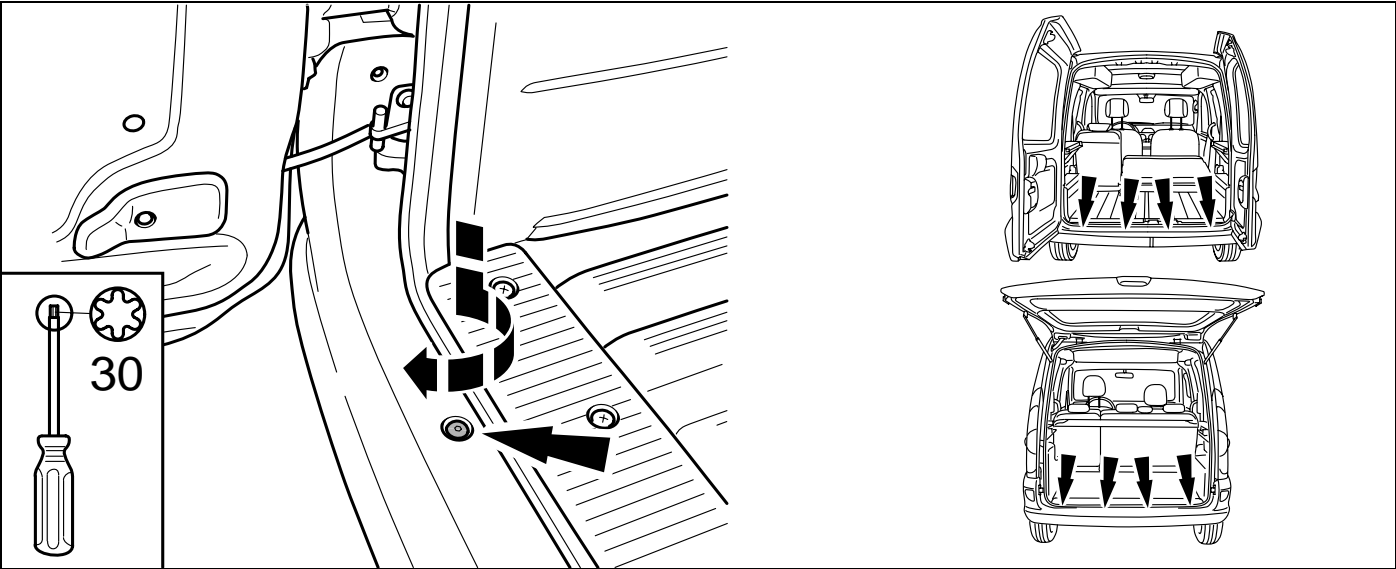

28

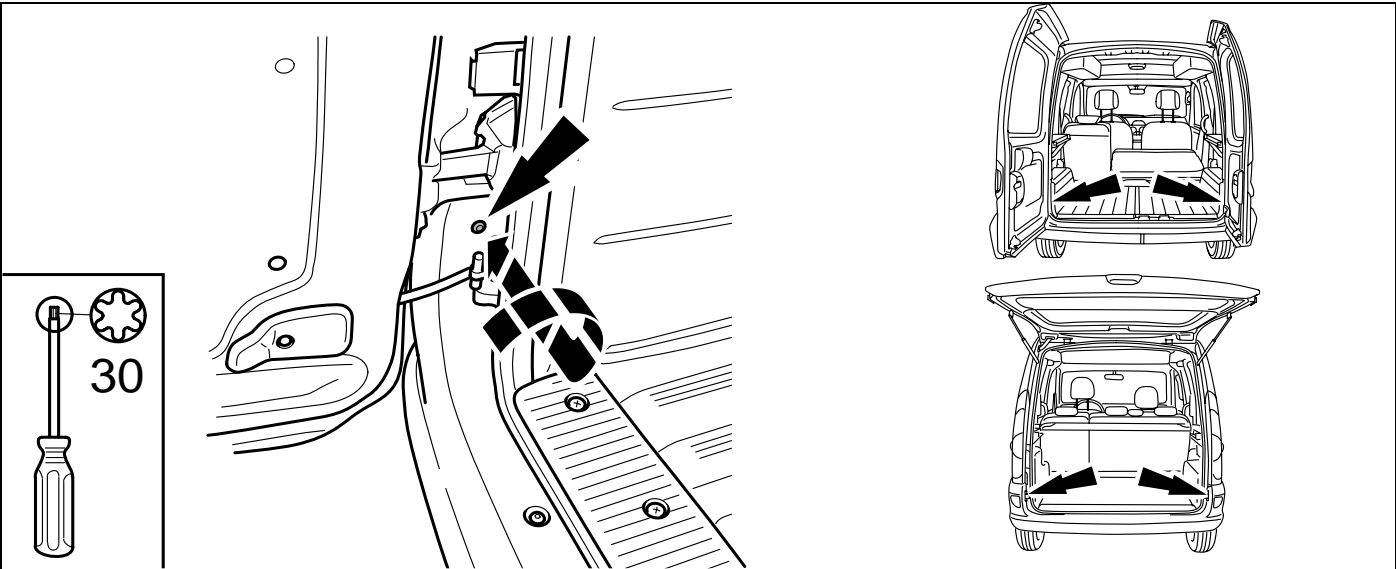

29

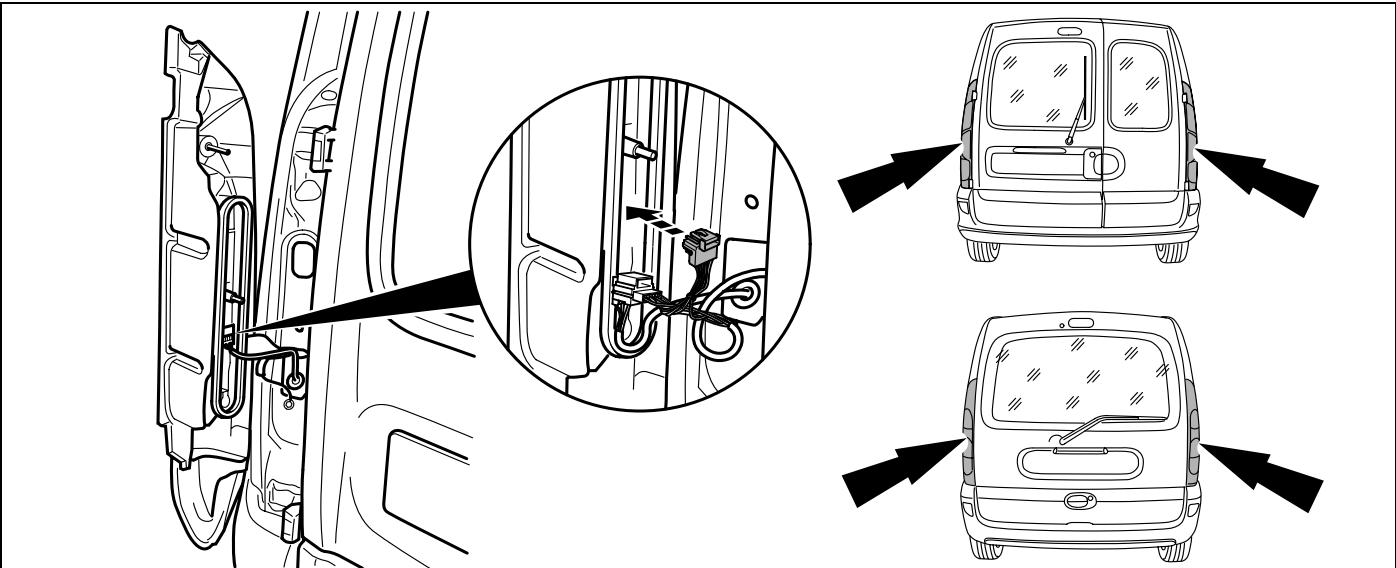

30

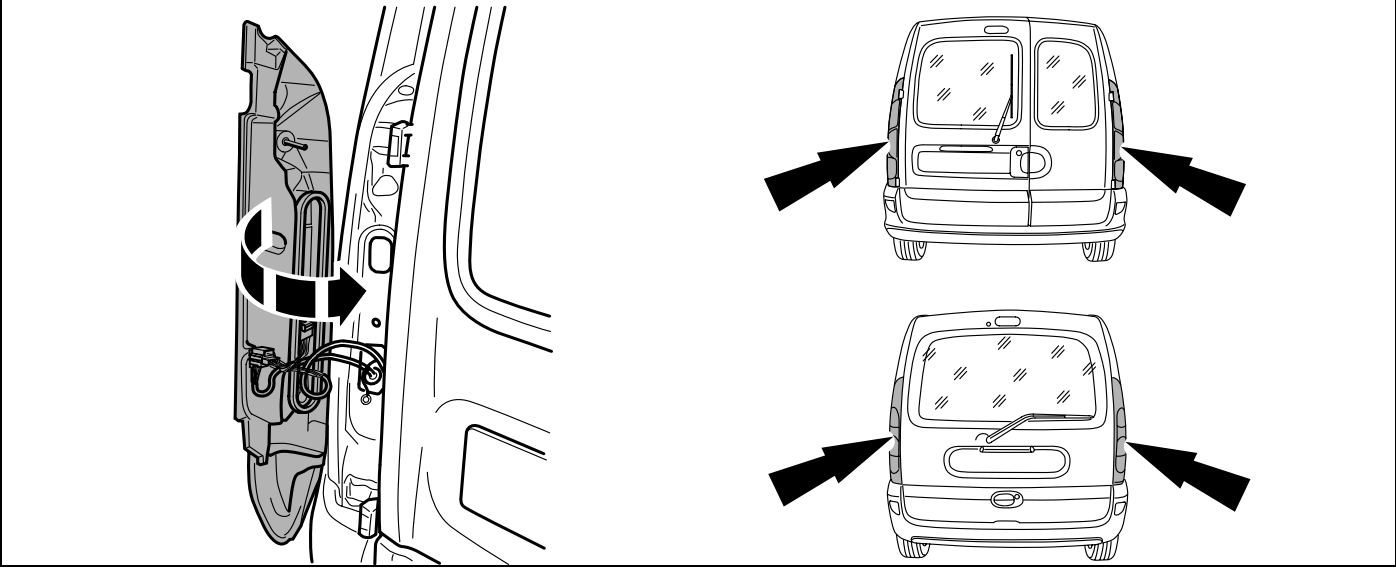

31

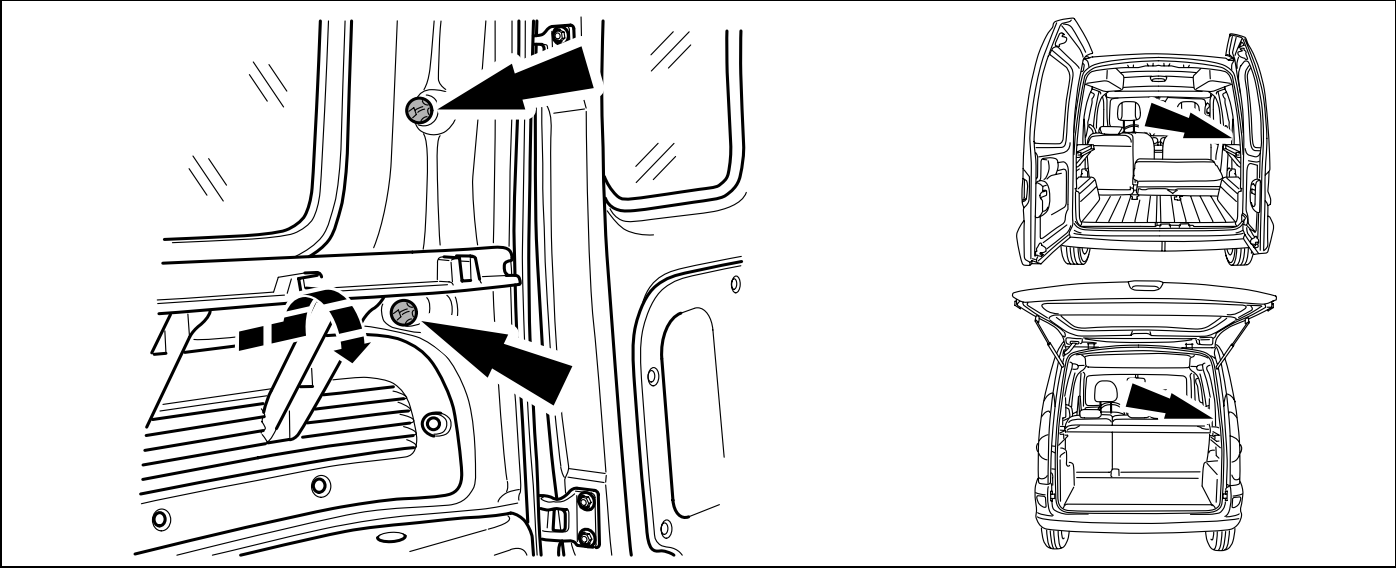

32

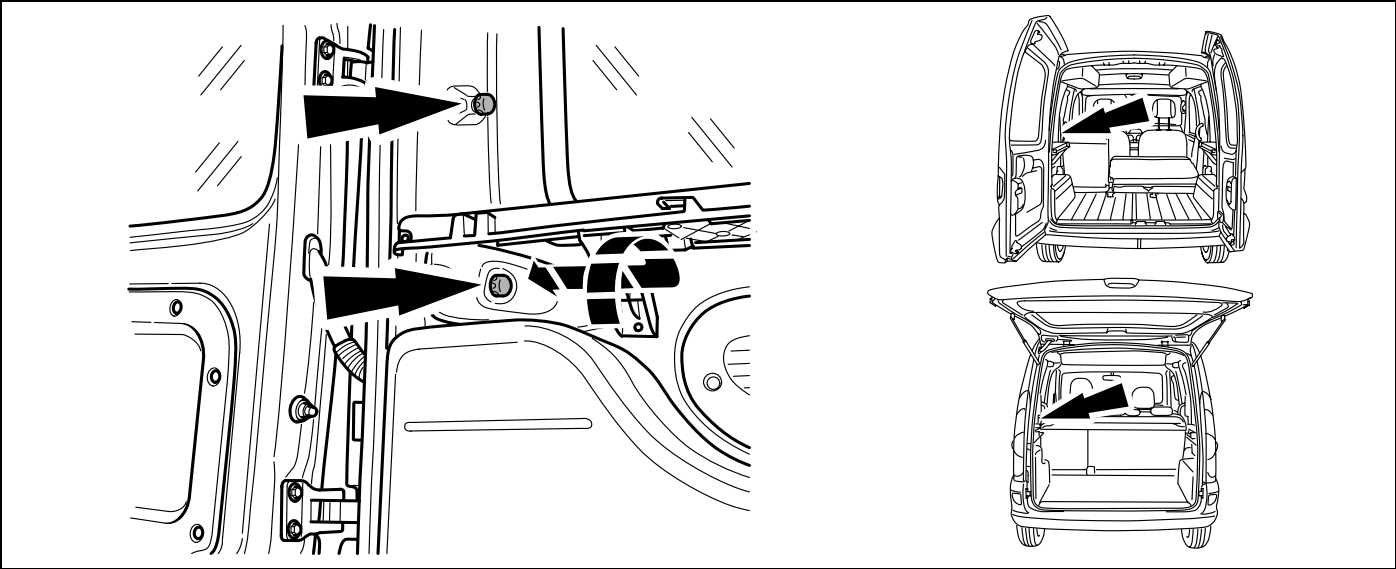

33**745008**

ERICH JAEGER-Artikelnummer:
ERICH JAEGER part number:

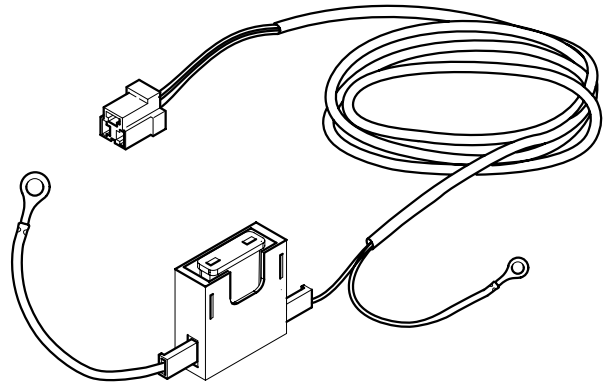
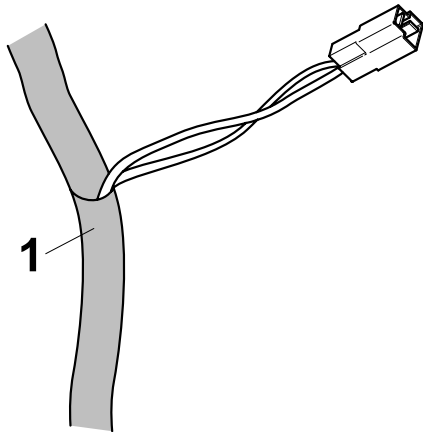
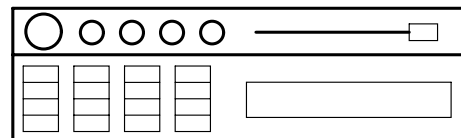
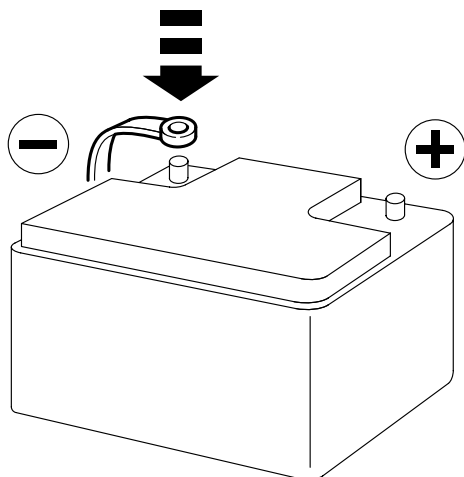
721407**34**

Radio Code

35

(D) Funktionen kontrollieren!

(GB) Check functions!

(F) Contrôler les fonctions!

(E) Compruebe las funciones!

(NL) Controleer functies!

(P) Verifique as funções!

(I) Controllare le funzioni!

(CZ) Zkontrolujte funkci!

(H) Ellenőrizze a funkciókat!

(PL) Sprawdź działanie!

(GR) Έλεγχος λειτουργίας!

(S) Kontrollera funktionerna!

(SLO) Preverite delovanje!

(TR) İşlevleri kontrol edin!

311069

311052

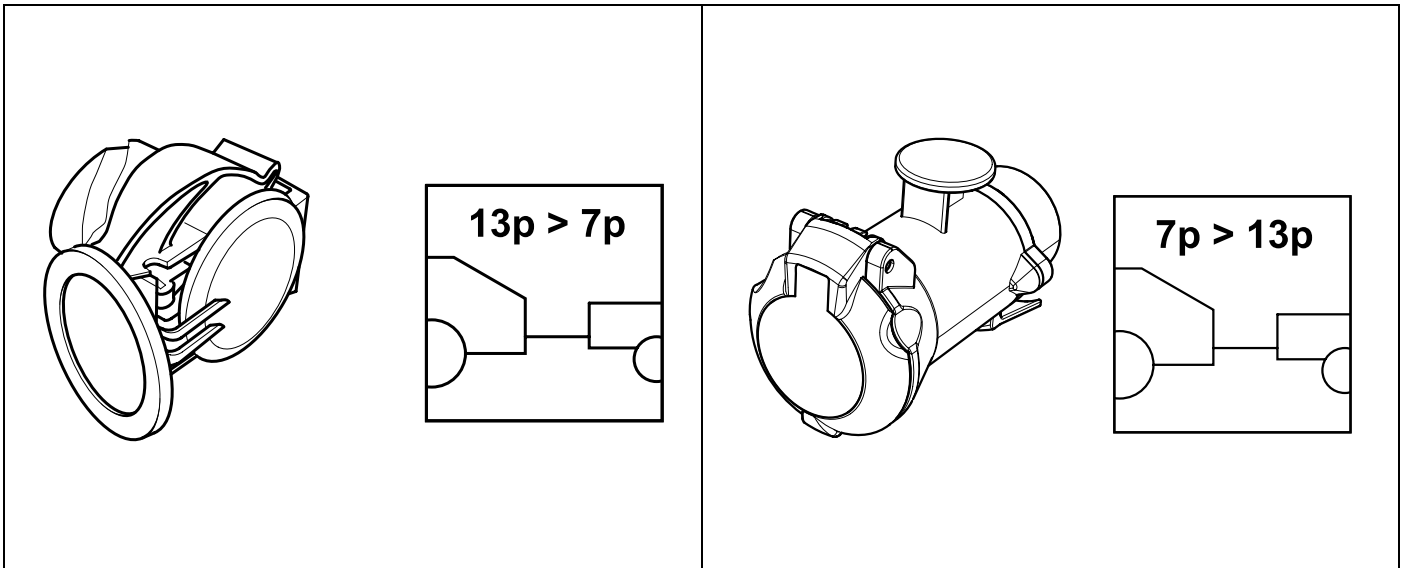

- | | |
|---|---|
| <p>(D) Technische Änderungen vorbehalten!</p> | <p>(CZ) Technická práva vyhrazena!</p> |
| <p>(GB) Subject to change!</p> | <p>(H) Műszaki módosítások joga fenntartva!</p> |
| <p>(F) Sous réserve de modifications techniques!</p> | <p>(PL) Zastrzegamy sobie możliwość wprowadzenia zmian technicznych!</p> |
| <p>(E) Salvo modificaciones técnicas!</p> | <p>(GR) Διατηρούμε το δικαίωμα των τεχνικών αλλαγών!</p> |
| <p>(NL) Technische wijzigingen voorbehouden!</p> | <p>(S) Ändringar förbehålls!</p> |
| <p>(P) Sujeito a modificações técnicas!</p> | <p>(SLO) Pravice do sprememb pridržane!</p> |
| <p>(I) Salvo modificaciones técnicas!</p> | <p>(TR) Teknik değışiklikler mahfuzdur!</p> |